

# INSTALLATION & SERVICE MANUAL

## Under-the-sink Reverse Osmosis System

### Reverse Osmosis Water Purification System



Made in USA

Member  
**WATER  
QUALITY  
ASSOCIATION**



**T**hank you for choosing Reverse Osmosis Drinking Water System. Read carefully and follow the instruction in this manual before proceeding with the actual installation. Pay particular attention to all warnings, cautions and notes. Failure to do so could result in personal injury or damage to the equipment or other property. Be sure to follow any special plumbing codes in your area.

### CHECK LIST:

- 1) Reverse Osmosis Unit
- 2) Four colored tubing --black, blue, red, yellow.
- 3) Water storage tank, 4 gallon volume (2.5 gallon @40psi).
- 4) Installation kit: tank ball valve, drain saddle valve, feed water valve, faucet assembly.
- 5) Manual and warranties.

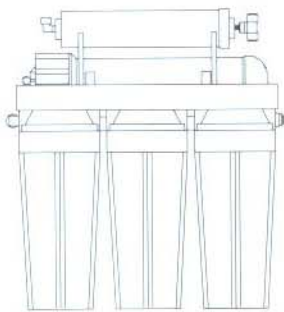

1) Reverse Osmosis Unit

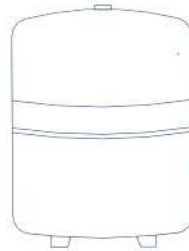

2) Water storage tank 4 gallon



3) Installation Kit

### RECOMMENDED TOOLS LIST

- ◆ Variable speed drill
- ◆ 1/8" and 1/4" drill bits
- ◆ 7/16" drill bit 1/2" and 9/16 open-end wrenches ( or adjustable)
- ◆ Phillips screwdriver
- ◆ Utility knife
- ◆ Teflon tape

- **WARNING:** Do not use this RO system appliance to purify non-drinkable sources of water that are unsafe or with water of unknown quality.
- **WARNING:** Never use hot water or freeze unit.
- **WARNING:** Incorrect installation will VOID the warranty.

## 5 Stage RO System Filtration Process

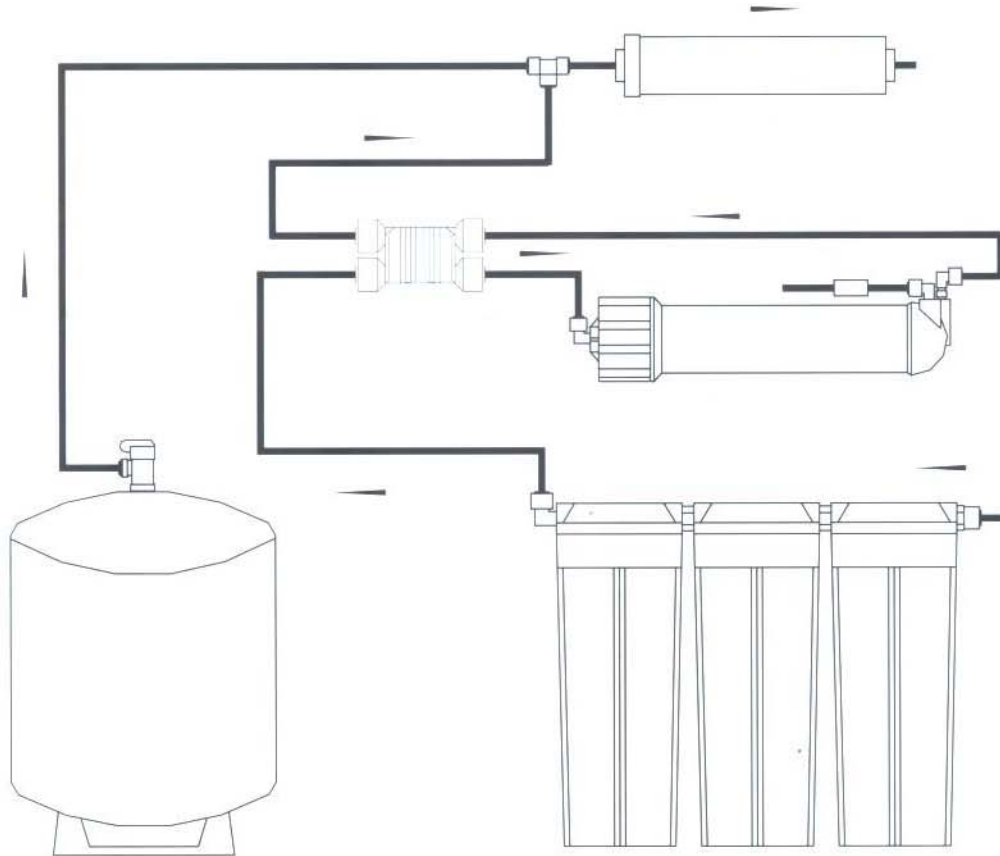

Stage	Description	Service Time
1 <sup>st</sup> stage	Sediment pre-filter	6-12 month
2 <sup>nd</sup> stage	Carbon block pre-filter	12-18 month
3 <sup>rd</sup> stage	GAC pre-filter	12-18 month
4 <sup>th</sup> stage	Membrane	24-36 month
5 <sup>th</sup> stage	Post carbon filter	16-18 month

### INSTALLATION QUICK LOOK

Please follow by 4 color coded tubing connection to complete installation

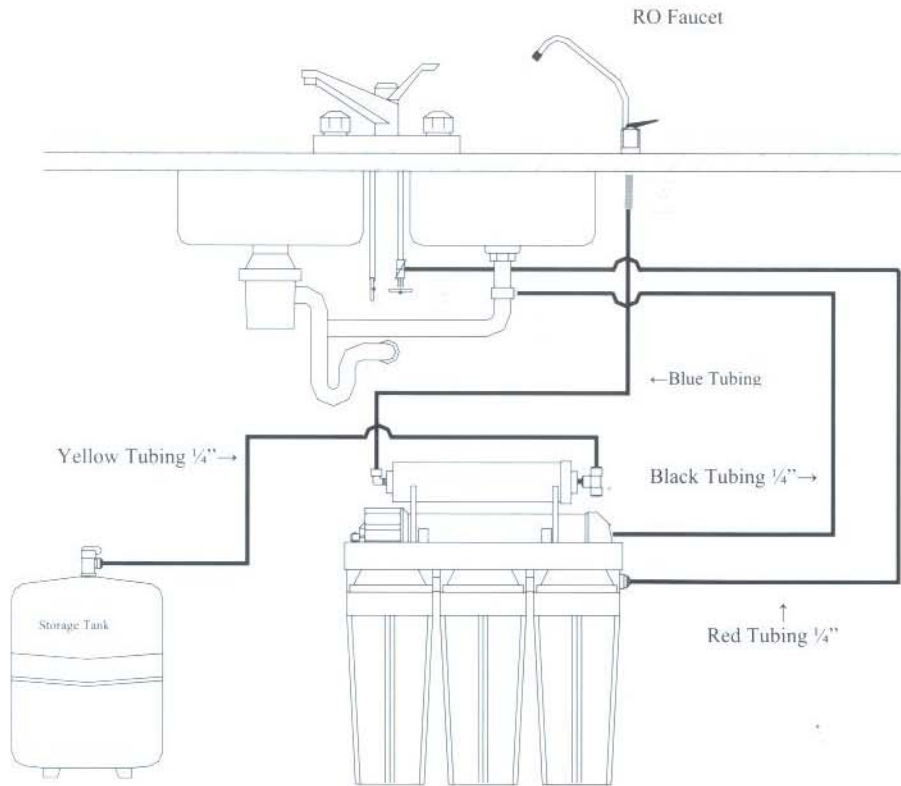

	<b>4 Connections</b>	<b>Item No.</b>	<b>Color of Tubing</b>	<b>Description</b>
<b>A</b>	RO Faucet	FU-NALR.C	Blue	Pure Water to the Faucet
<b>B</b>	Feed Water Valve	VV-WNV-4 VV-WWC-1	Red	Feed Water to RO System
<b>C</b>	Tank Ball Valve	VV-BLP014WJG	Yellow	Pure Water to Storage Tank
<b>D</b>	Drain Connector	VV-DSP014	Black	Discharge Water to Drain

**CAUTION:** When cutting supplied tubes, predetermine the length by measuring the distance between the components to be connected.

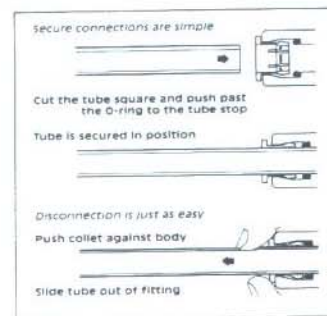

## INSTALLATION

### STEP 1: INSTALLING THE FAUCET

- 1) Determine the desired location for your RO faucet (FU-NALR.C) on your sink surface.
- 2) Place a piece of masking tape or duct tape on the determined location where hole is to be drilled.
- 3) Use a variable speed drill at slow speed with a 1/8" (3 mm) drill and drill a centering hole in the center of the desired faucet location. Use lubricating oil to keep the drill bit cool while drilling.
- 4) Enlarge the hole using a 1/4" (6.4 mm) drill bit. Use factory approved method or approved plumbing practice to drill hole in sink.
- 5) Enlarge the hole to 7/16" (11 mm) diameter. Keep bit well oiled and drill slowly.
- 6) Pass the small rubber washers, the chrome base plate and the large rubber washer in that order over the threaded mounting tube at the base of the faucet.
- 7) From under the sink, install the large metal (or plastic) washer and the star washer over the threaded stem. Screw on the nut and tighten.
- 8) Sleeve over the brass compression nut and the white plastic ferrule (do not use the brass one) over blue tubing and push to the end of the threaded stem. Screw on the compression nut and tighten.

Please see <Fig. 1> and <Fig. 2>

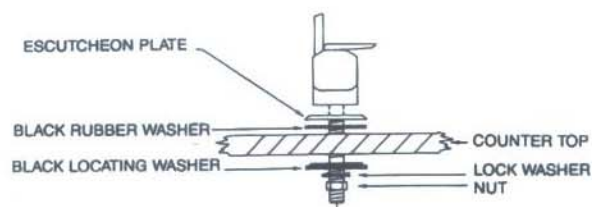

<Fig. 1>

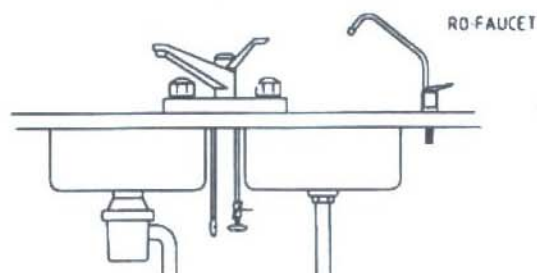

<Fig. 2>

- 9) Pull out the 3/8" O.D. red tube from RO faucet and insert the stainless steel long reach sprout into the faucet base while holding the black faucet handle in horizontal position.
- 10) The spout is 360° swivel.
- 11) The faucet handle can be pushed down for instant and pull out for continue flow.

**STEP 2: TAPPING INTO COLD WATER LINE**

**Caution: The water supply to your unit MUST be from the COLD WATER LINE. Hot water will severely damage your R.O. System.**

- 1) Locate cold water angle shut off valve underneath the sink and turn it off. Open cold water faucet to release the pressure. On single handled faucets, the hot water may have to be turned off to prevent any hot water cross over. If water continues to come out of faucet with angle valve turned off, the house main will have to be turned off.
- 2) Locate feed water adapter in the installation kit. The angle needle valve(VV-WNV-4) should be installed into slip joint adapter (VV-WWC-1) before assembly is connected to feed water line. See <Fig. 3> (Teflon tape must be used on angle valve to prevent leaks).
- 3) Disconnect the cold water riser tube and install the slip joint adapter.



&lt;Fig. 3&gt;

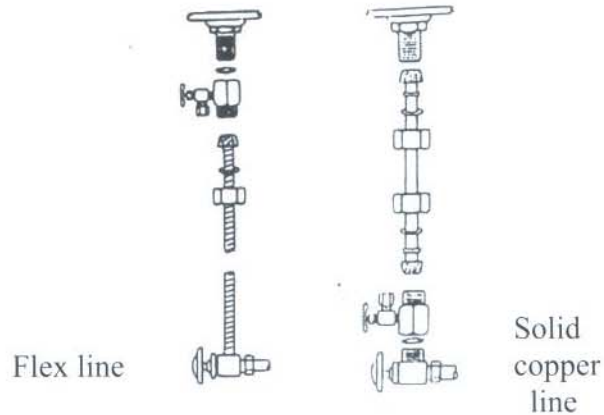

&lt;Fig. 4&gt;

- 4) Please follow by <Fig. 4> for flex line and solid copper riser installation.
  - a) Flex line:  
Loosen nut and separate cold water riser tube from faucet shank. Gently bend riser tube so that slip joint fits onto faucet shank. Replace the existing cone washer with new washer provided in installation kit onto cold water riser tube. Reinstall riser tube onto slip joint adapter and tighten.
  - b) Solid copper riser tube:  
Procedure as flex tubing except you must cut a piece of the riser tube about  $\frac{3}{4}$ " or 1" so the slip joint adapter can fit between faucet and riser tube (Teflon tape must be used on slip joint adapter to prevent leaks).
- 4) Connect red tubing to angle needle valve (VV-WNV-4).

**STEP 3: MOUNTING THE TANK BALL VALVE**

**Note: Do not tamper with the air valve on low side of storage tank. It has been preset at 8-10 psi by the manufacturers.**

- 1) Unplug the plastic cap on the top of the tank.
- 2) Wrap the thread 3 times with plumbers (Teflon) tape only.
- 3) Connect the ball valve to the thread. Make sure it is tight but not over-tight. See <Fig. 5>.
- 4) Connect the yellow tubing from to the tank ball valve
- 5) Turn the tank ball valve off.

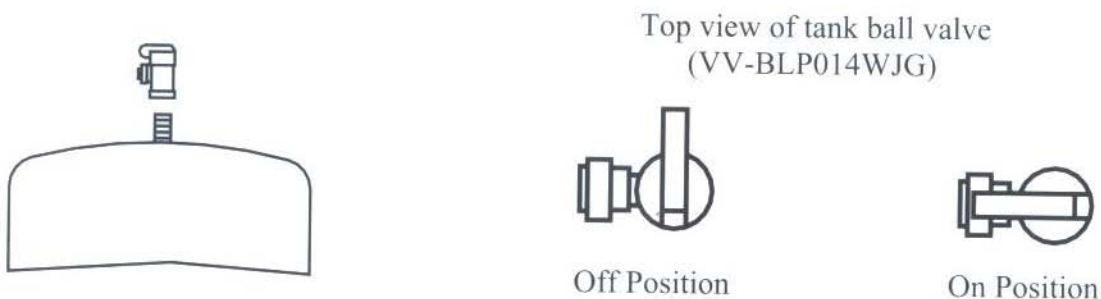

&lt;Fig. 5&gt;

**STEP 4: MOUNTING THE DRAIN CLAMP**

The drain clamp (VV-DSP014) will fit most standard drain pipe 1/4". It should be installed above the trap and on the vertical or horizontal tailpiece. See <Fig. 6>

- 1) Position the drain saddle in desired location, mark spot through thread outlet, remove saddle.
- 2) Drill 1/4" (6.3mm) hole into the drain pipe above the water line of trap.
- 3) Align the hole drilled in the drain pipe with the drain saddle using a drill bit or other narrow straight object and tighten clamp.
- 4) Make sure to align drain saddle to drilled hole. Attach drain saddle to drain pipe and tighten the two screws evenly. See <Fig. 7>.
- 5) Connect black tubing to drain clamp.

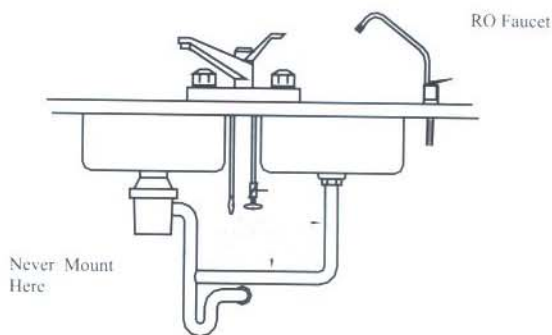

&lt;Fig. 6&gt;

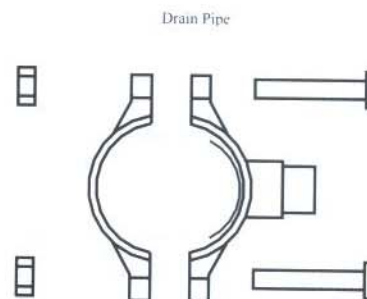

&lt;Fig. 7&gt;

**STEP 5: SYSTEM START UP**

- 1) Turn on the cold water supply and the under sink feed water valve (VV-WNV-4) but close the tank ball valve (VV-BLP014WJG).
- 2) Open RO faucet (FU-NALR.C) (black lever to the up position) for continue flow.
- 3) Check system for leaks, tighten as necessary.
- 4) After 5 minutes, the water will start to drip out of the RO faucet. Let it drip for about 10 minutes and then flip the handle to the closed position. Turn on the tank ball valve now. It will now take several hours (2-3) for the storage tank to fill, depending on the local water pressure.

**DO NOT DRINK THE WATER FROM THE FIRST TANK PRODUCED BY YOUR NEWLY PURCHASED SYSTEM**

- 5) After the tank is full (you will hear the water stop), flush the system by placing the RO faucet in the open position until the water is completely discharged.
- 6) Upon complete discharge of storage tank, flip handle to closed position on RO faucet and let the refilling process begin. This process could take 2-3 hours to complete.
- 7) After the second tank is filled, you may enjoy the pure water.
- 8) Check leaks daily for first week and periodically thereafter.
- 9) You may notice that the water may be milky colored during the first week. It is the air bubble in the water. It is normal and safe.

**CLEANING PROCEDURES**

The following system and tank cleaning procedures are recommended every 12-18 months.

- 1) Shut off the source water supply to the RO system.
- 2) Open the RO faucet and depressurize the RO system and storage tank.
- 3) Remove pre-filter cartridges, post-filter cartridges, and RO membrane. Discard or prepare for clean. If the RO membrane element is to be reused, disinfectant solution should be introduced into the permeate tube outlet sufficient to remove biofilm in this vulnerable area, before reinserting the membrane into the housing.
- 4) Wash the internal housing areas with warm soapy water using a clean brush (do not scratch the surface of the housings). Be sure to clean o-ring grooves thoroughly. Remove the existing o-ring. Discard o-ring or prepare for cleaning.
- 5) Rinse off all housing pieces with clean water to remove soap.
- 6) Replace o-rings, and lubricate per manufacture's instruction.
- 7) Pour recommended amount of disinfection solution into each of the clean housings and replace housing on the RO system.
- 8) Disconnect RO storage tank from the system.
- 9) RO storage tank cleaning procedure:

**Recommended items:**

- Tank sanitizer feeder or small filter housing with fittings and tubing, see <Fig. 8>
- Disinfectant solution
- Pressure gauge and air pump

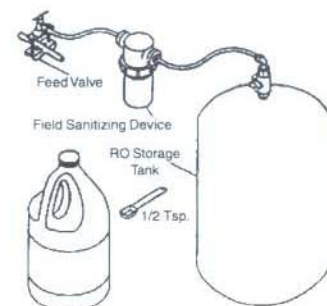

<Fig. 8>



- a) The tank should be empty. Check the air precharge pressure with an accurate gauge (low pressure type 0-12 lbs.). The average tank pressure should be 6-8 psi (when the tank is empty).
  - b) Fill the tank sanitizer feeder with the recommended disinfectant dosage, and connect the feeder to the water supply and RO storage tank.
  - c) Turn on water supply and force water and disinfectant solution into the RO storage tank. The storage tank should feel heavy when filled.
  - d) The disinfectant solution should remain in the tank a minimum of 10 minutes. If the tank has not been sanitized in over a year, leave the solution in for 20 to 30 minutes. Turn off the water supply valve and the RO storage tank valve. Disconnect the sanitizer feeder, and connect the RO storage tank to the RO unit (the tank ball valve should remain closed).
- 10) Open the feed water valve and open the RO faucet until water flows freely from the spout. Close the RO faucet. Hold the disinfectant solution in the RO system, including the tubing and faucet, for a minimum of 10 minutes. Open the tank ball valve.
  - 11) Shut off the feed water valve and open the RO faucet. Let water run out until the flow stops at the RO faucet.
  - 12) Open the feed water valve. Let water flow freely from the faucet for three minutes. Shut off the water at the source water supply with RO faucet open.
  - 13) When the flow of water has stopped at the RO faucet, remove the filter housing sumps and membrane housing from the RO system. Replace the filters and membrane according to the service life.
  - 14) Replace the housings on the RO system. Open the source water valve and allow the water to flow from the faucet.
- Because some of the disinfectant may still be in the system, the system should be flushed prior to using the water for human consumption.
  - A maintenance record should be kept for the RO system, including information about the replacement parts, when service was performed, and by whom.

## **PREVENTIVE MAINTENANCE**

This recommendation is intended for maximum efficiency of RO water production by your system.

### **1) Filter maintenance**

- a) It is OK to put filters on the shelf for several years.
- b) To keep the sealed, non-opened filter, we recommended to put it into some air-tight container, preventing it from absorbing the air. This prolongs the shelf life of carbon filter (particularly, if you order the replacement filter more than one year usage) and avoid any possible odor from the air.

### **2) Membrane maintenance**

- a) The dry packed membrane usually has a two-year shelf life. To prolong the shelf life, we recommended to keep non-opened dry membrane in refrigerator.

- b) Once being used, we recommended you to run the RO system every day, at least 10-15 minutes (about 1 gallon or 4 liter drinking water). This helps to maintain the membrane performance.
- c) If not use RO system for weeks, drain the storage tank first. Fill the tank and drain it twice. And then your RO system is ready to use.

### 3) Filter and membrane change procedures:

- a) Shut off the water supply.
- b) Turn off the tank ball valve by turning 90 degree.
- c) Open RO faucet to up continue flow position.
- d) Lift the filter housing up 1" and slid the housing wrench in (not supply with systems). Use one hand to hold the system and the other hand to turn the wrench clockwise to open the housing.

**Note: If it is too tight to open the housing you may try to unplug the fitting between red tubing and the systems in order to reduce the air and water pressure inside the housing**

- e) After opening the housing, remove the used filter and put the new filter into the housing. Make sure the O-ring is placed and turn the housing counter-clockwise to close.
  - f) Repeat previous step on the second filter change.
  - g) Turn on the water supply and make sure no leaks.
  - h) Let the water drip from faucet for about 10 minutes. If the water flow is less than 1 cup (8 oz. or 240 ml) per minute, it may be a signal to membrane.
  - i) Membrane change procedures:
    - Unscrew the cap of the membrane housing.
    - Slid out the used membrane and discard.
    - Insert the new membrane with 2 o-rings into housing first, the black brine seal around membrane latter. Be sure it is fully seated into bottom end
    - Screw cap back on to the membrane housing, make sure o-ring is still in place.
    - It may take 10-20 minutes for new membrane to run to normal flow.
- If the water flow is OK, then turn on the tank ball valve. After 1 minute, turn off the RO faucet and complete the filter change procedures.

**TROUBLE SHOOTING****Note: Turn off the system before servicing.**

<b>PROBLEM</b>	<b>CAUSE</b>	<b>SOLUTIONS</b>
Milky colored water	✓ Air in system	<input type="checkbox"/> Air in the system is a normal occurrence with initial startup of the RO system. This milky look will disappear during normal use within 1 to 2 weeks.
Noise from faucet	✓ Air gap faucet ✓ Location of drain saddle ✓ Restriction in drain line	<input type="checkbox"/> Will disappear after system shut down <input type="checkbox"/> Relocate the drain to above water trap. <input type="checkbox"/> Blockage sometimes caused by debris from garbage disposal or dishwasher
Small amount of water in storage tank	✓ System just starting up  ✓ Air pressure in storage tank is low	<input type="checkbox"/> Normally it takes 2-3 hours to fill tank. Low water pressure and/or temperatures can reduce production rate. <input type="checkbox"/> Add pressure to storage tank. The pressure should be 8-10 psi when the tank is empty
Slow production	✓ Low water pressure ✓ Crimps in tubing ✓ Clogged prefilters ✓ Fouled membrane	<input type="checkbox"/> Add a booster pump <input type="checkbox"/> Make sure tubing is straight <input type="checkbox"/> Replace prefilters <input type="checkbox"/> Replace membrane
Water taste or smell Offensive	✓ Post carbon is depleted ✓ Fouled membrane ✓ Sanitizer not flushed out	<input type="checkbox"/> Replace post carbon <input type="checkbox"/> Replace membrane <input type="checkbox"/> Drain storage tank and Refill it overnight
No drain water	✓ Clogged flow restrictor	<input type="checkbox"/> Replace flow restrictor
Leaks	✓ Fittings are not tightened  ✓ Twisted O-ring ✓ Misalignment of hole in drain saddle	<input type="checkbox"/> Tighten fittings as necessary <input type="checkbox"/> Replace a o-ring <input type="checkbox"/> Realign drain saddle

## LIMITED TWO YEAR WARRANTY

### 1. WHAT YOUR WARRANTY COVERS:

Reverse Osmosis Systems are warranted to the original owner to be free of defects in material and workmanship from the date of manufacture for two years as follows:

- 1) Manufacturer will, within two years of purchase, replace the defected parts (excluding the replaceable filters) at no charge.
- 2) The replaceable filters are warranted for defects in material and workmanship only. Service life of replaceable filter varies with local water and is thus not warranted.

### 2. CONDITIONS OF WARRANTY:

- 1) System must be maintained and serviced with manufacturer approved replacement parts and filters. The performance and functioning of your drinking water system is directly related to the quality of the being treated and the particular application in which it is used. Therefore, manufacturer's liability is limited to the cost of repair or replacement (at our option) of any defective part, does not include incidental or consequential damages of any kind. The warranty gives you specific legal rights and may also have other rights which vary from state to state.
- 2) Systems must be installed and operated in accordance with manufacturer's recommended procedures and guidelines.

### 3. WHAT REVERSE OSMOSIS SYSTEMS WILL NOT DO:

- 1) Warranty is void if product failure or damage results from freezing, neglect, misapplication, fouling with sediment or scale or failure to operate the system in accordance with the instructions contained in the owners manual.
- 2) The following operating conditions must also be followed for this warranty to be valid.

### 4. OBTAINING WARRANTY SERVICE:

For warranty service, ship your Reverse Osmosis unit (less tank) to your dealer, freight and insurance prepaid, with proof of date of original purchase and Return Merchandise Authorization (RMA) No.

### 5. LIMITATIONS AND EXCLUSIONS:

Manufacturer will not be responsible for any implied warranties, including those of merchant ability and fitness for a particular purpose. Manufacturer will not be responsible for any incidental or consequential damages, including travel expense, telephone charges, loss of revenue, loss of time, inconvenience, loss of use the equipment and damage caused by the equipment and its failure to function properly. This warranty sets forth all of manufacturer's responsibilities regarding this equipment.